

**Corporate Network Solutions
 Business Networks Systems Division**

**Technical
 Information
 Bulletin**

TITLE:

AD-8 Rev 2 Voicemail System

SYSTEM APPLICATION:

ICS MODEL 110/120
 IVS 2000 / ICS M110/120 Retrofit Systems

SOFTWARE VERSION APPLICATION:

3800 SERIES CH 3.02 (ICS M110/120)
 R2.1 SOFTWARE (IVS 2000 / ICS M110/120 Retrofit Systems)
 6.65 Q414H AD-8 Software

ATTACHMENTS:

Doc-Reg ID: TM0084_1

<http://www.kbase.cns.nec.com.au/>

TABLE OF CONTENTS

1	GENERAL DESCRIPTION	2
2	HANDLING PRECAUTIONS	2
3	HARDWARE / SOFTWARE REQUIREMENTS (PABX)	3
3.1	Required Hardware	3
3.2	Required Software	4
4	INSTALLATION PROCEDURES	5
4.1	Installation Precautions	5
4.2	Mounting PZ-VM00 and PZ-VM01 Card	5
4.3	Mounting AP00 Card (Optional)	10
4.4	Cable Running for MCI Connection (Optional)	12
4.5	Maintenance Console Connection	13
4.5.1	Direct Connection	13
4.5.2	Remote Connection	13
4.6	Connection of MCI cable for download of VMS Soft Keys (IVS2000 ONLY)	16
5	PROGRAMMING PROCEDURE	17
5.1	Programming Digital Voicemail Ports	17
5.2	Live Record Feature Programming	19
5.3	Data Programming for MCI (Optional for CCIS No.7 ICS M120 only)	19
5.4	Data Programming for Advanced AAINFO/VMS Soft Keys	21
5.4.1	Advanced AAINFO Assignment	21
5.4.2	VMS Soft Key Assignment	23
5.5	Data Programming for Internal Modem	24
6	AD-8 CONFIGURATION	25
6.1	Preferred Default settings	25
6.2	Tone detection	25
6.3	MCI configuration	25
6.3.1	Manual MCI Configuration	26
6.3.2	Automatic MCI Configuration	26
6.4	Upgrading from previous versions to Q414H.	26
6.5	Backup, Archive and Restore	27
6.5.1	Definitions	27
6.5.2	Backup Feature	27
6.5.3	Archive Feature	27
6.5.4	Restore Feature	28
6.5.5	The BRU Utility	28
6.5.6	Other methods of backup, restore and archive	28
7	SERVICE CONDITIONS	29
8	MAINTENANCE	29

1 GENERAL DESCRIPTION

The NEAXMail AD-8 Rev 2 is a card type voice processing system with various features. The board is mounted into the LT slots of a PABX in the same manner as other line/trunk circuit cards. Active Voice Corporation provides the software, whereas NEC supplies the hardware. The voice processing circuits were designed by BICOM Corporation.

The basic system of the NEAXMail AD-8Rev 2 provides 4 voice mail ports. By adding an extension card, an additional 4 voice ports are available (total of 8 ports). The illustration below shows the system outline of the NEAXMail AD-8 Rev 2.

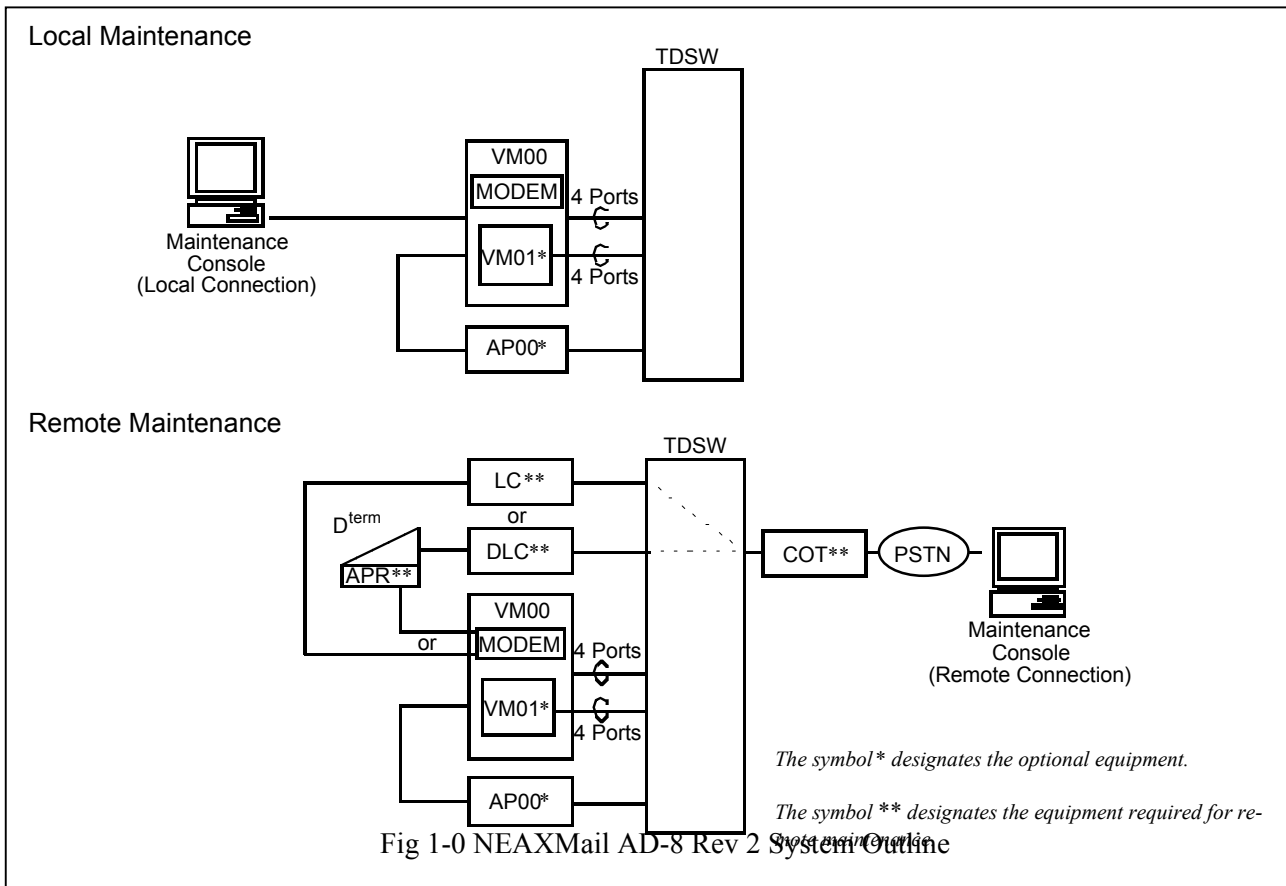

2 HANDLING PRECAUTIONS

Due to the static sensitive nature of this and other boards within PABX's, it is necessary to exercise ESD procedures when handling the card.

Also, since the Hard Disk Drive comprises of moving parts, it is necessary to minimize the shock that is experienced by the unit. Foam packaging that comes with the box should be used if the Hard Disk Drive is to be placed on a surface prior to installation (i.e. if it is not going to be inserted in the PABX).

If the PABX PIM is to be moved, then the PZ-VM00 should be removed. The card should always be transported in the packaging that it comes in. A reminder notice can be seen when the box is first opened.

Note: Please keep the original packaging in case transportation of the PZ-VM00 is required.



CAUTION !!

**HARD DISK DRIVE IS MOUNTED ON THIS CARD. HANDLE CAREFULLY.
BUMPING/ JARING THE CARD MAY CAUSE INTERNAL HARD DISK DAMAGE.**

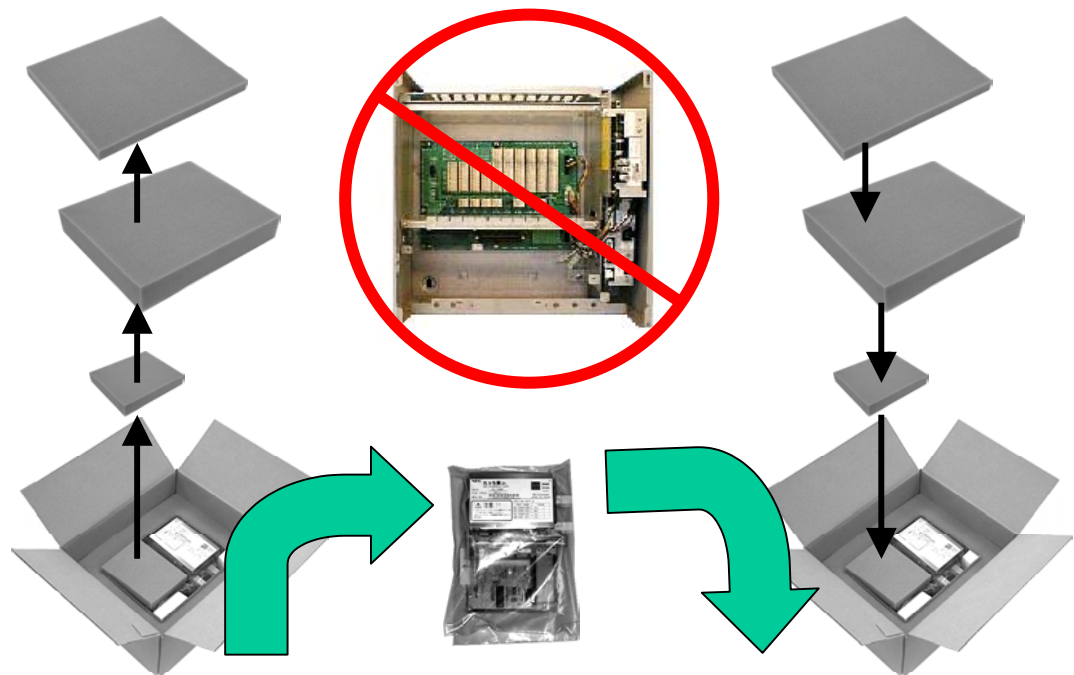

Fig 2. Handling procedures for NEAXMail AD-8

2.1 Removal of PZ-VM00 from a powered-up PIM

The PZ-VM00 can safely be removed from the powered-up PIM, **ONLY** when the SWP lamp on the PZ-VM00 card is illuminated.

To remove: place the MB key on the PZ-VM00 card in the up position and wait for SWP lamp to illuminate (approx 20secs). Remove the card from PIM

To reinstall in PIM: insert into LT slot with MB key in up position, set MB key in the down position and press reset key on the PZ-VM00 card. The card will be online when green lamp on PZ-VM00 card is illuminated (approx 4-5mins).

To install the NEAXMail AD-8 on a PABX, the following equipment is required.

- PZ-VM00 Card: This card consists of a digital signal processor complete with port interface (4 ports), central processor unit for controlling various data, hard disk unit to read/write the voice mail

application program and voice mail information, and an internal modem (14.4 Kbps) for remote maintenance. Moreover, this card provides 4 digital line circuit interfaces, and is mounted into an LT slot of the PABX. One card per PABX is available.

- **PZ-VM01 Card:** This card provides additional 4 ports for transmitting/receiving voice information, and is used for expanding the port interface to 8 ports, being mounted on the PZ-VM00 card.

For providing the NEAXMail AD-8 with MCI (Message Centre Interface) connection, which is required for MW lamp setting via CCIS No. 7, the following equipment is required:

- **PN-AP00-A Card:** This card continually supervises the status of the NEAXMail AD-8 on MCI connection, and stores the call information into its internal memory if the NEAXMail AD-8 is not ready. Capability of storing call information is limited to 16 calls. **This card is not required when AD-8 is installed in the IVS 2000 PABX.**
- **AP VM-0.7 CA-A, AP RS-0.3 CA-F, AP RS-0.8 CA-F:** One of these cables is used to connect between the NEAXMail AD-8 and the PN-AP00-A card based on RS-232C. The cable is also used for a once-off download of VMS Soft Key data from VM-00 card to MP card of PABX.

For connecting a Maintenance Console to NEAXMail AD-8, the following equipment is required:

- **RS RVS-15 CA-A, RS RVS-4 CA, MAT CA-P/R:** One of these cables is used to connect a Maintenance Console to the NEAXMail AD-8 directly.
- **LC/DLC, COT Cards:** For remote maintenance using internal modem on the PZ-VM00 card, an LC-COT connection is required on the PABX. If the PABX has no analog line circuit, a DLC card with an Analog Port Adapter is required instead of an LC card.

3.2 Required Software

The minimum version of PABX software for this product is 3800 CH3.02 software for ICS M110/120 and R1 for IVS 2000. The minimum PN-AP00 firmware for ICS M110/120 is SC2556 V1.0.

Note: *The minimum hardware version for the PN-AP00-A is version 6A.*

The following table indicates the minimum software levels required for the features provided with AD-8 Rev 2.

Feature	PABX software reqd
VMS Live Recording	ICS M110/M120: 3500 or higher IVS 2000: R1.0 or higher
VMS Live Record Soft Keys (Dterm 75 series handset only)	ICS M110/M120: 4100 or higher IVS 2000: R1.0 or higher
VMS Soft Keys (Dterm 75 series handset only)	ICS M110/M120: Not supported IVS 2000: R2.1 or higher

4 INSTALLATION PROCEDURES

4.1 Installation Precautions

The PZ-VM00 card contains a hard disk unit and many delicate components. When handling the VM00 card, basic safety precautions should be followed to protect the card against mechanical, vibration and electric shock, including the following:

- Do not turn the power of the PABX off before making busy the PZ-VM00 card. Before power off, you must confirm that the SWP lamp on the PZ-VM00 card is lit after you turn the MB switch to ON (up position). Powering off without make busy may damage files in the hard disk on the PZ-VM00 card.
- Before programming the PABX system data, set the MB switch on the PZ-VM00 card to ON (up position), and let the MB switch remain ON while programming.

4.2 Mounting PZ-VM00 and PZ-VM01 Card

STEP-1 Note the structure of the PZ-VM00 card switch locations of each board.

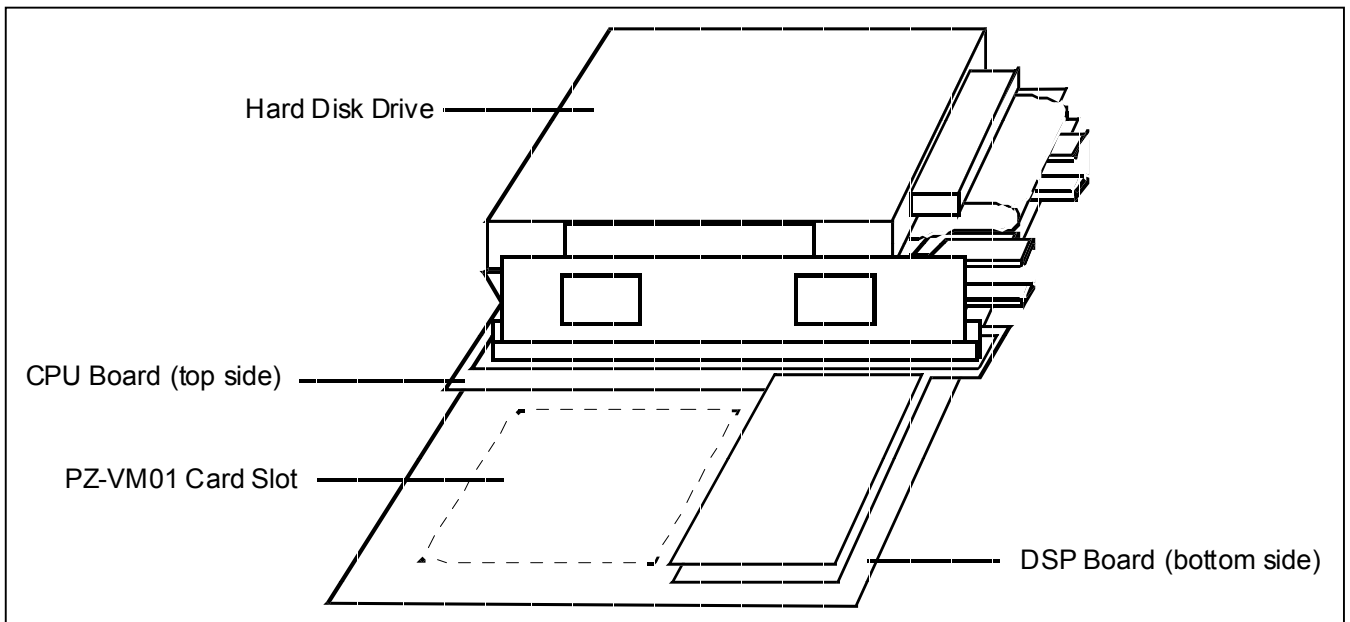

Fig 4-1 Basic layout of the PZ-VM00

The PZ-VM00 card has a two-story structure, consisting of a DSP board and a CPU board. The illustration below shows the locations of the switches, lamps and connectors provided on the DSP board, CPU board of the PZ-VM00 card, and the VM01 card.

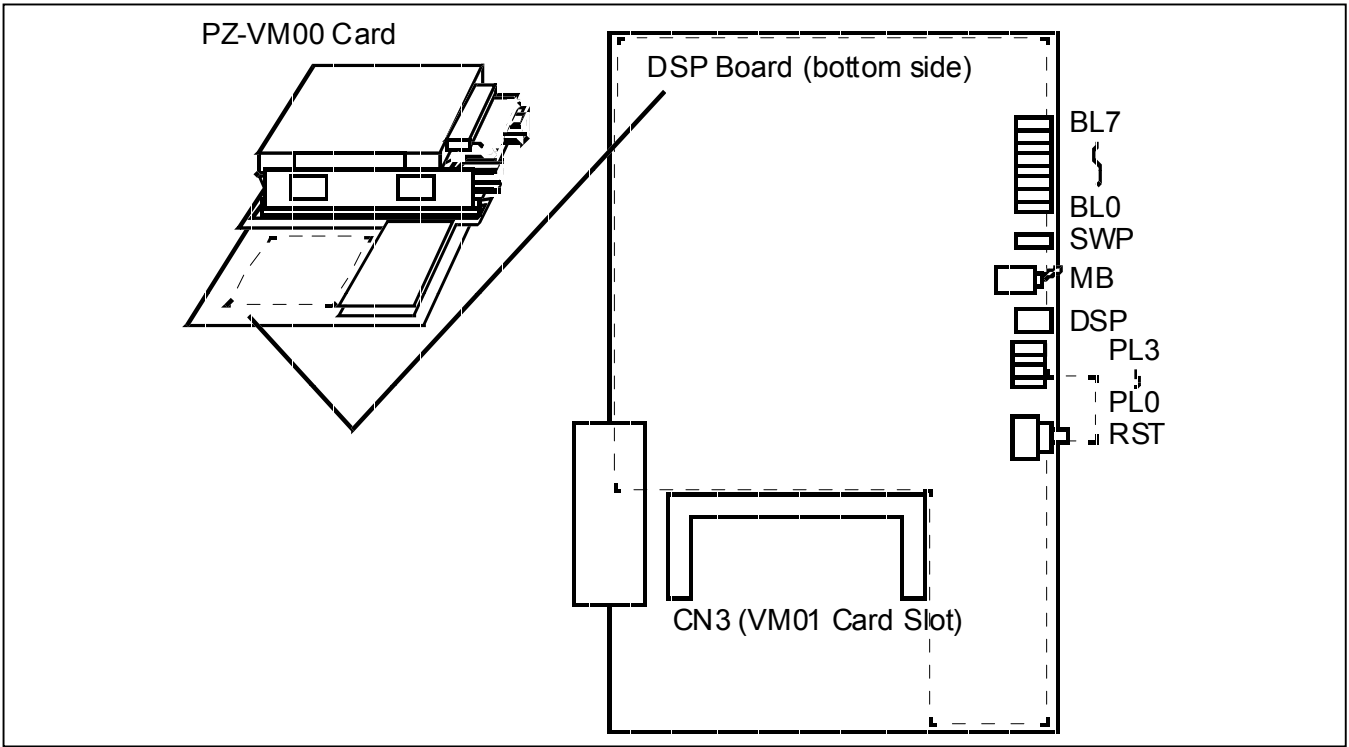

Fig 4-2 Switch/Lamp layout of the DSP Board

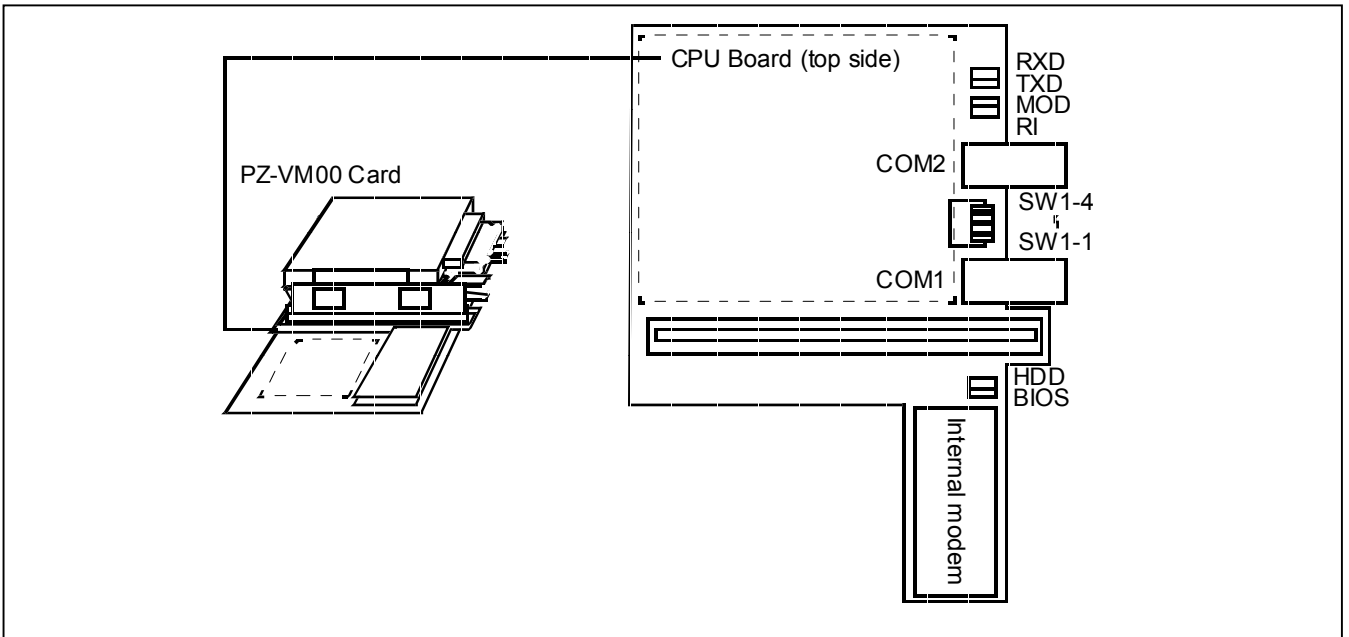

Fig 4-3 Switch/Lamp layout of the CPU Board

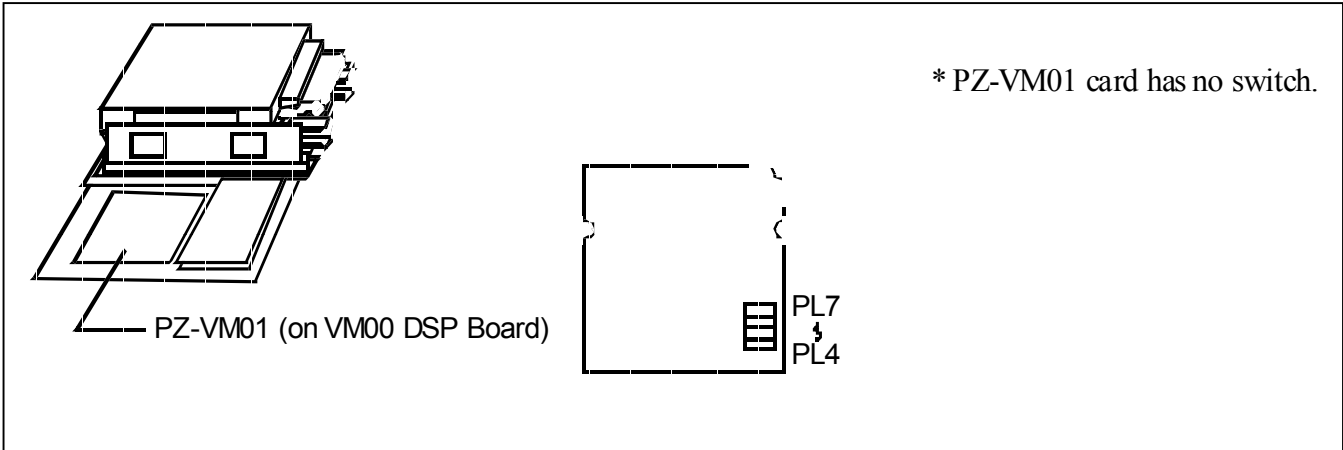
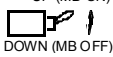

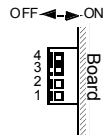

Fig 4-4 Basic layout of the PZ-VM01 Board

STEP-2 Before mounting the card into a slot on the PABX, set the MB switch to up position, and set the other switches to appropriate position according to the system specifications. The function of each switch is described in the following table.

The brackets “[]” in the table shows the standard setting position of each switch.

Switch Name	Switch No.	Position	Description	Remarks
MB 	—	UP	For make busy	When plugging/unplugging the card, be sure to set MB switch to up position.
		DOWN	For normal operation	
RST 	—	—	Push when starting up this card, after MB switch is set to down position.	Note
SW1 	1	ON	BIOS Redirect Utility (Keyboard)	Use BIOS Redirect only when assisted by NEC.
		[OFF]	Normal Operation	
	2	ON	BIOS Redirect Utility (Floppy Drive)	Use BIOS Redirect only when assisted by NEC.
		[OFF]	Normal Operation	
	3	ON	COM2: Use internal modem for remote maintenance	—
		OFF	COM2: RS-232C (for local direct connection to maintenance console)	
	4	[OFF]	Not used	—
	Note			

Note: When SW1 settings have changed, RST switch must be pushed.

STEP-3 If additional 4 ports (8 ports total) are required, insert the PZ-VM01 card in the slot on the PZ-VM00 card obliquely, and push down the PZ-VM01 card.

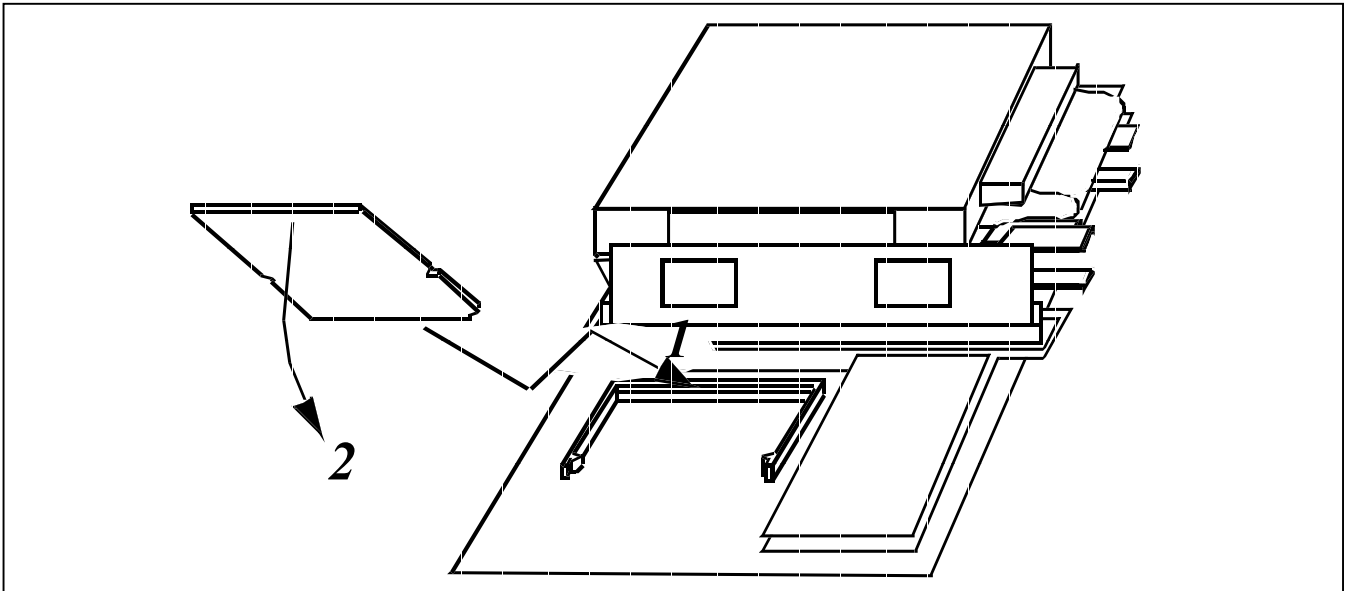

STEP-4 Mount the PZ-VM00 card into the following LT slot. The card occupies three physical slot's width to left side from its own.

When mounting IVS 2000 PIM; LT00 slot

When mounting 72 ports PIM : LT00 slot

When mounting 64 ports PIM : LT02-LT15 slot

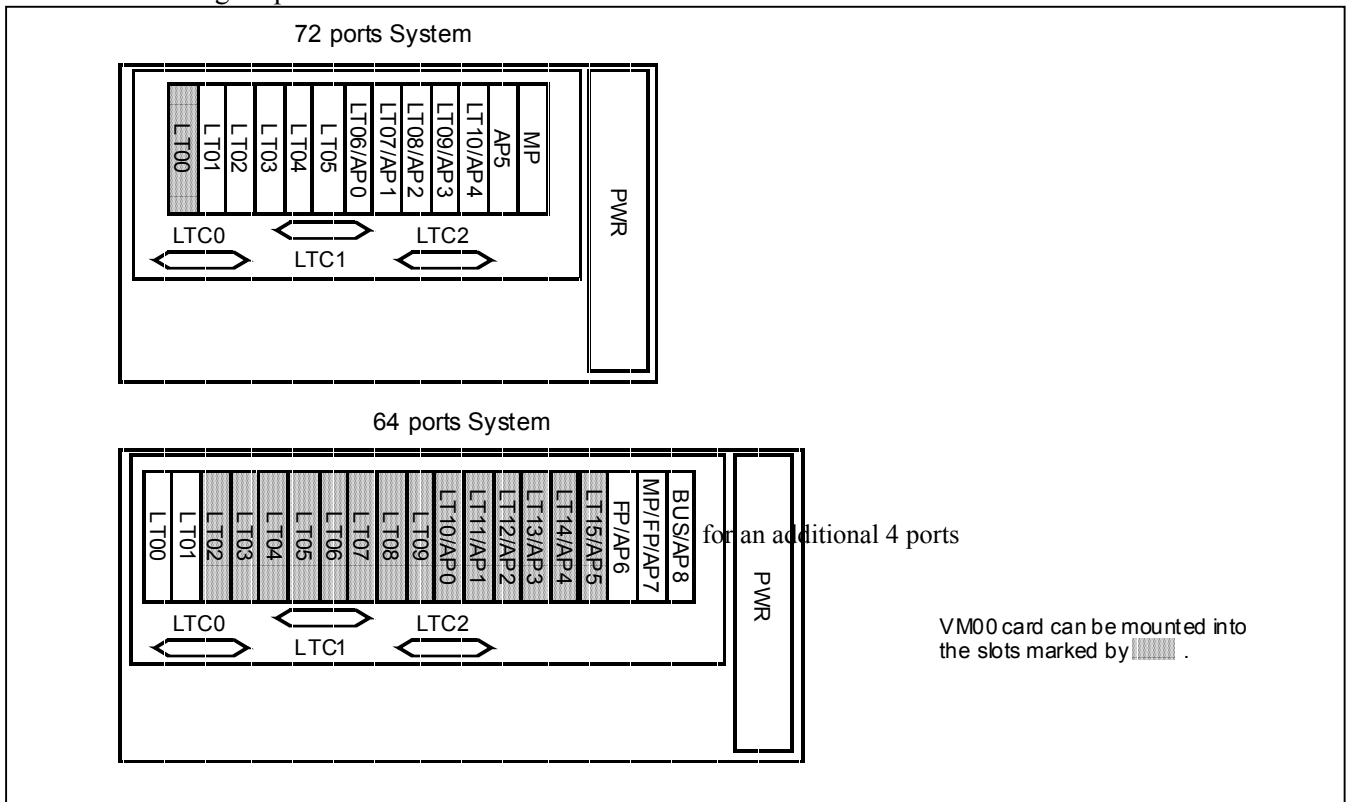

Fig 4-6 Mounting locations of the PZ-VM00

Note: When mounting VM00 card on 64 ports PIM, mount the card into the odd numbered slot if possible. If the card is mounted in an even numbered LT slot, the odd numbered LT slot to the right can not be used because the last four ports of the voice mail will be assigned to these LENSs. In other words, mounted in an even numbered LT slot will require 4 LT slots instead of 3.

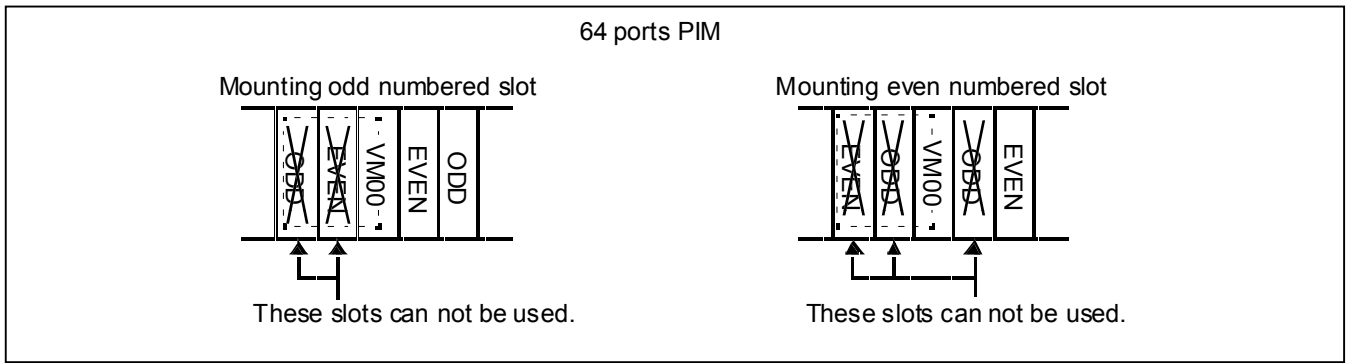

Fig 4-7 LT Slot occupation of the PZ-VM00

STEP-5 Set the MB switch to the down position, and then push the RST switch.

STEP-6 Check the lamp indications of the card referring to the following table.

If the lamp indicates an unusual state, refer to “Lamp Indications and Remedial Actions” in the “MAINTENANCE” section of this manual.

Location	Lamp Name	Color	Function
VM00 Card CPU Board	RXD	Green	Lights when the internal modem on this card is transmitting the data.
	TXD	Red	Lights when the internal modem on this card is receiving the data.
	MOD	Red	Lights when COM2 port is used for internal modem (When SW1-3 is set to ON).
	RI	Green	Lights when ringing.
	HDD	Red	Flashes when loading BIOS bootstrap programs (When this card is starting up), and when accessing the internal Hard Disk Drive. If the internal Hard Disk Drive has some problem, this lamp does not light.
	BIOS	Red	Lights when BIOS program starts, and goes out when DOS program starts.
VM00 Card DSP Board	BL0-7	Red	Lights when the corresponding circuit is in use. Flashes at 60 IPM when corresponding circuit is in make busy state or the system data for the circuit is not assigned.
	SWP	Red	Lights when about 30 seconds have elapsed since MB switch is set to ON. This card can be unplugged while this lamp lights.
	DSP	Green	Lights or flashes according to the VMS application program.
		Red	
PL0-3	Red	Lights when the corresponding DSP port is used.	
VM01 Card	PL4-7	Red	Lights when the corresponding DSP port is used.

4.3 Mounting AP00 Card (Optional)

An AP00 card is required when the system provides MCI (Message Centre Interface). This is required **ONLY** when installing the PZ-VM00 in the ICS M120 and CCIS No.7 in a network situation. This card is not required when AD-8 is installed in the IVS 2000 PABX.

Mount the AP00 card according to the following steps. For details regarding MCI, refer to the MCI (Message Centre Interface) System Manual.

STEP-1 On the AP00 card, set the MB switch to ON and set other switches to appropriate position as shown in the following illustration and tables.

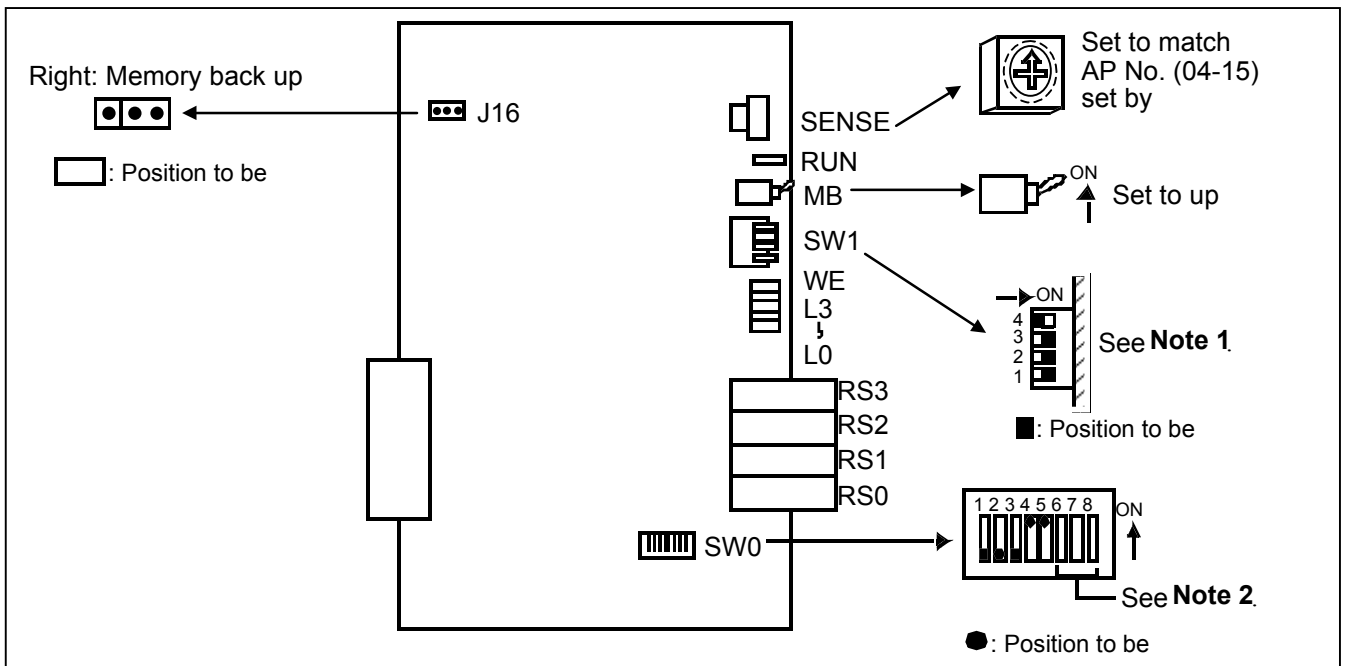

Fig 4-8 PN-AP00-A switch/lamp/connector layout.

Switch No.	On Line	Off Line
SW1-4	OFF	OFF
SW1-3	ON	OFF
SW1-2	ON	OFF
SW1-1	ON	ON

Note 1: The SW1 is used to select the AP operating mode as shown above.

On line: Normal operation mode. The AP should always be in the "On line", other than when you delete the AP data.

Off line: The mode for AP data clearing by the CMD100/CMD101.

Note 2: Set the SW0-6, 7, 8 as the following table.

Switch No.	Setting Position	Function
SW0-6	ON	Set No.0 port forcibly in a state which DSR signal is always provided.
	OFF	Receive DSR signal from the DCE on No.0 port.
SW0-7	ON	Set No.1 port forcibly in a state which DSR signal is always provided.
	OFF	Receive DSR signal from the DCE on No.1 port.
SW0-8	ON	Set No.2 port forcibly in a state which DSR signal is always provided.
	OFF	Receive DSR signal from the DCE on No.2 port.

When the DCE connected to the port does not provide a function to send the DSR signals, set the switch to ON. In this case, the AP00 card can not recognize the actual state of the DCE, so that the call records or system messages will not be stored in the memory buffer of the A P00 card, even if the cable is disconnected from the DCE.

When the switch is set to OFF the call records or system messages will be stored when the cable is disconnected and will be sent when the cable is reconnected.

STEP-2 Mount the card into an AP slot on the PIM.

STEP-3 Set the MB switch to OFF on the AP00 card.

4.4 Cable Running for MCI Connection (Optional)

STEP-1 Set the MB switch on the VM00 card to up position.

CAUTION: Do not unplug the VM00 card until the SWP lamp lights up. The SWP lamp lights after approximately 30 seconds have passed since the MB switch was set to the up position.

STEP-2 Connect between the AP00 card and the VM00 card using the following cable. Use the RS1 connector on the AP00 card, and the COM1 connector on the VM00 card for this connection.

STEP-3 Set the SW1-1 switch to ON, the MB switch to down, then push the RST switch, on the VM00 card.

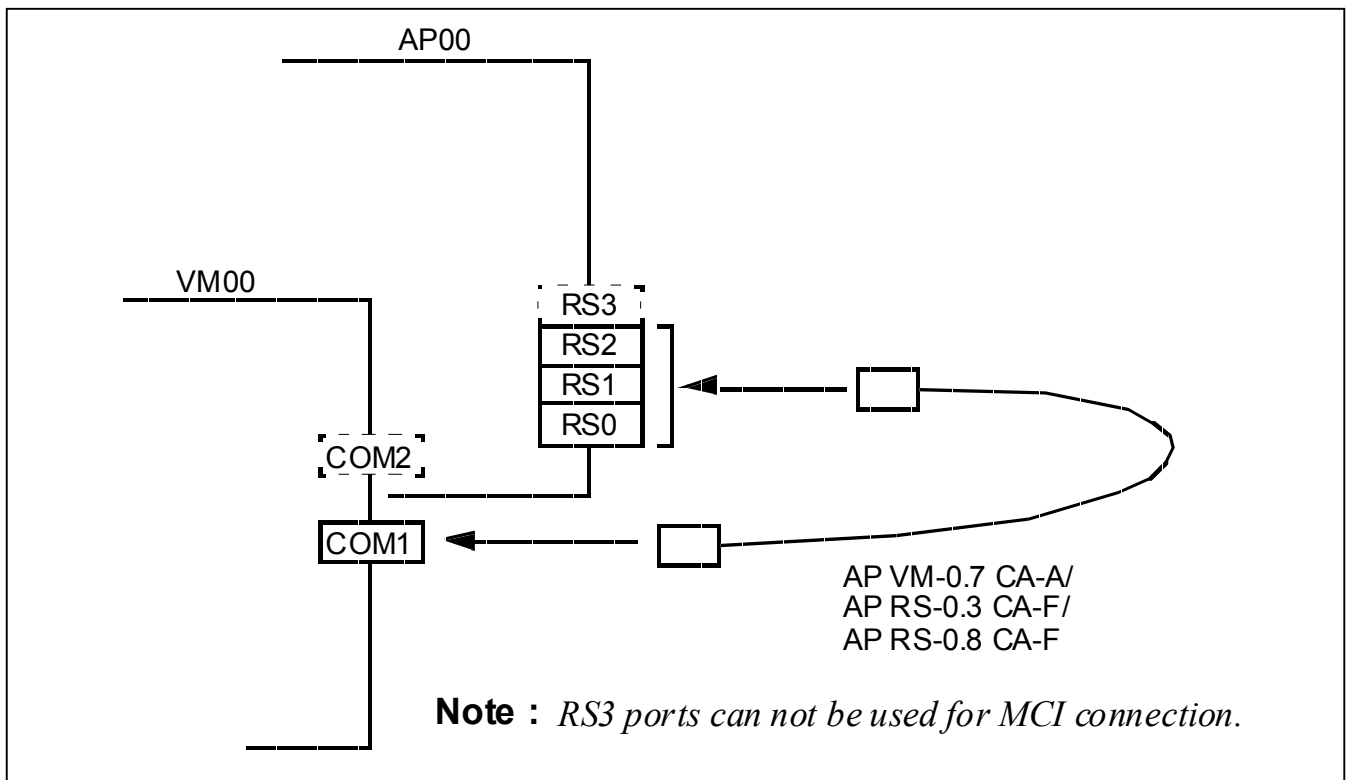

Fig 4-9 MCI connection for the PZ-VM00

4.5 Maintenance Console Connection

4.5.1 Direct Connection

STEP-1 Set the MB switch on the VM00 card to up position.

CAUTION: Do not unplug the VM00 card until the SWP lamp lights. The SWP lamp lights when about 30 seconds have passed since the MB switch was set to up position.

STEP-2 Connect the maintenance console to COM2 on the VM00 card by the following cable.

STEP-3 Set the SW1-3 switch to OFF, the MB switch to down, then push the RST switch, on the VM00 card.

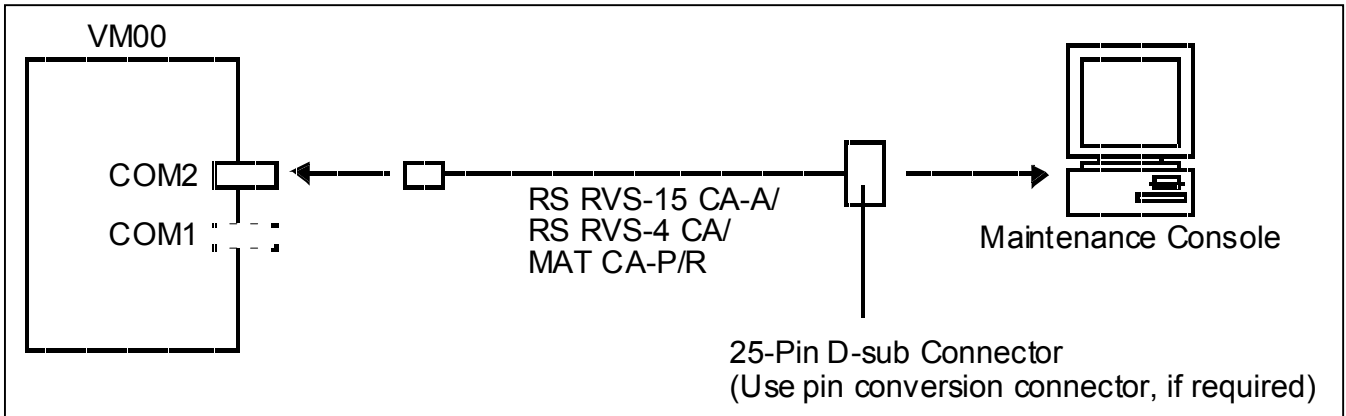

Fig 4-10 Direct Maintenance Console Connection

4.5.2 Remote Connection

For remote maintenance the internal modem on the VM00 card is used.

The modem lines of the VM00 card are connected to the last row pins of the slot to which the VM00 card is mounted, and is connected with the LC card via the BWB-LTC-MDF.

When the system has no LC card, a DLC card and a Dterm with APR (Analog Port Adapter with Ringing) can be used instead of the LC card. The following illustration shows the summary of the connection.

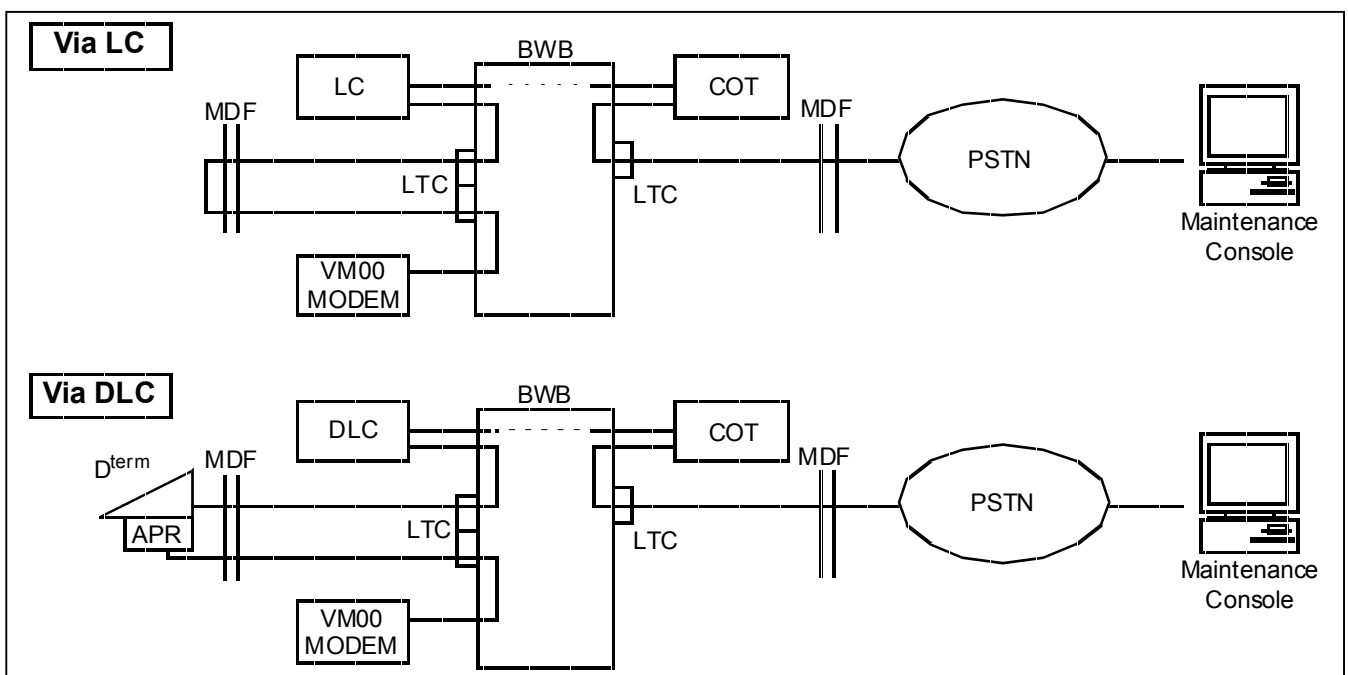

Fig 4-11 Remote Maintenance Console Connection

STEP-1 Mount the LC/DLC and COT card into the LT slot on the PIM.

For system data programming for internal modem, refer to next section 4.4 “Data Programming for Internal Modem”.

STEP-2 Connect the VM00 card modem lines to the LC card on the MDF.

OR

Connect the VM00 card modem lines and the DLC card via a D term with APR.

The illustrations below show the example of the MDF cross connection.

STEP-3 Set the SW1-3 switch to ON, the MB switch to the down position, then push the RST switch, on the VM00 card.

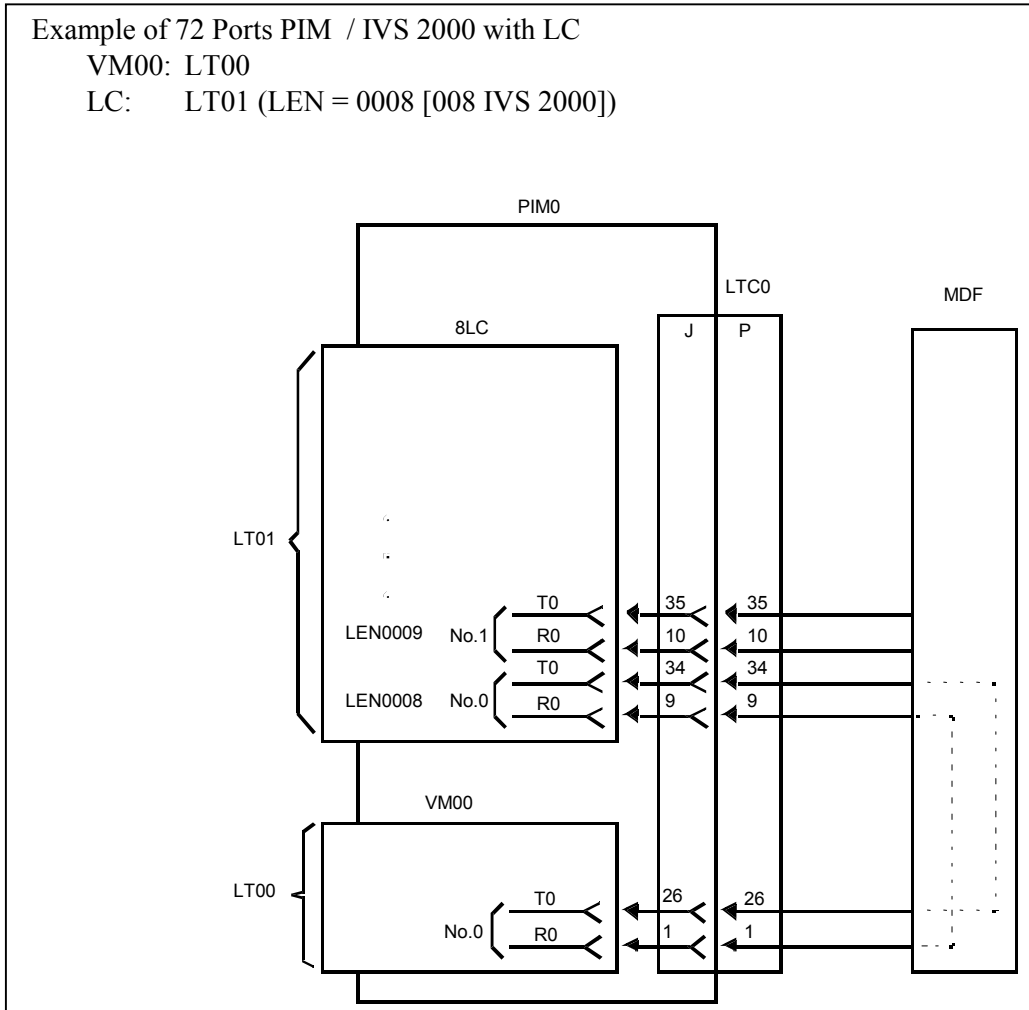

Fig 4-12 LC to VM00 connection for a 72 port PIM

Example of 64 Ports PIM with LC

VM00: LT03

LC: LT04 (LEN = 0016)

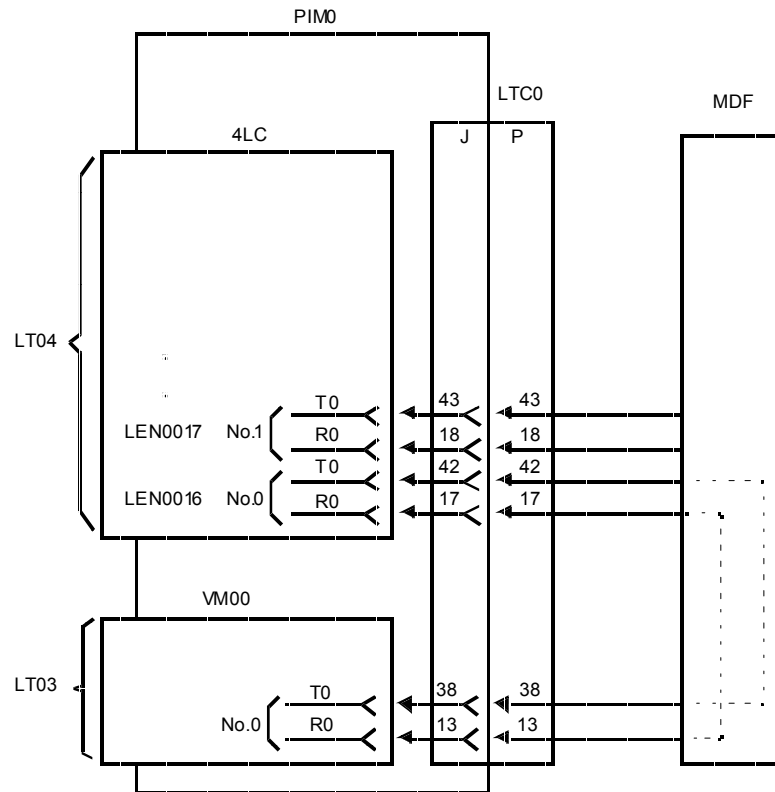
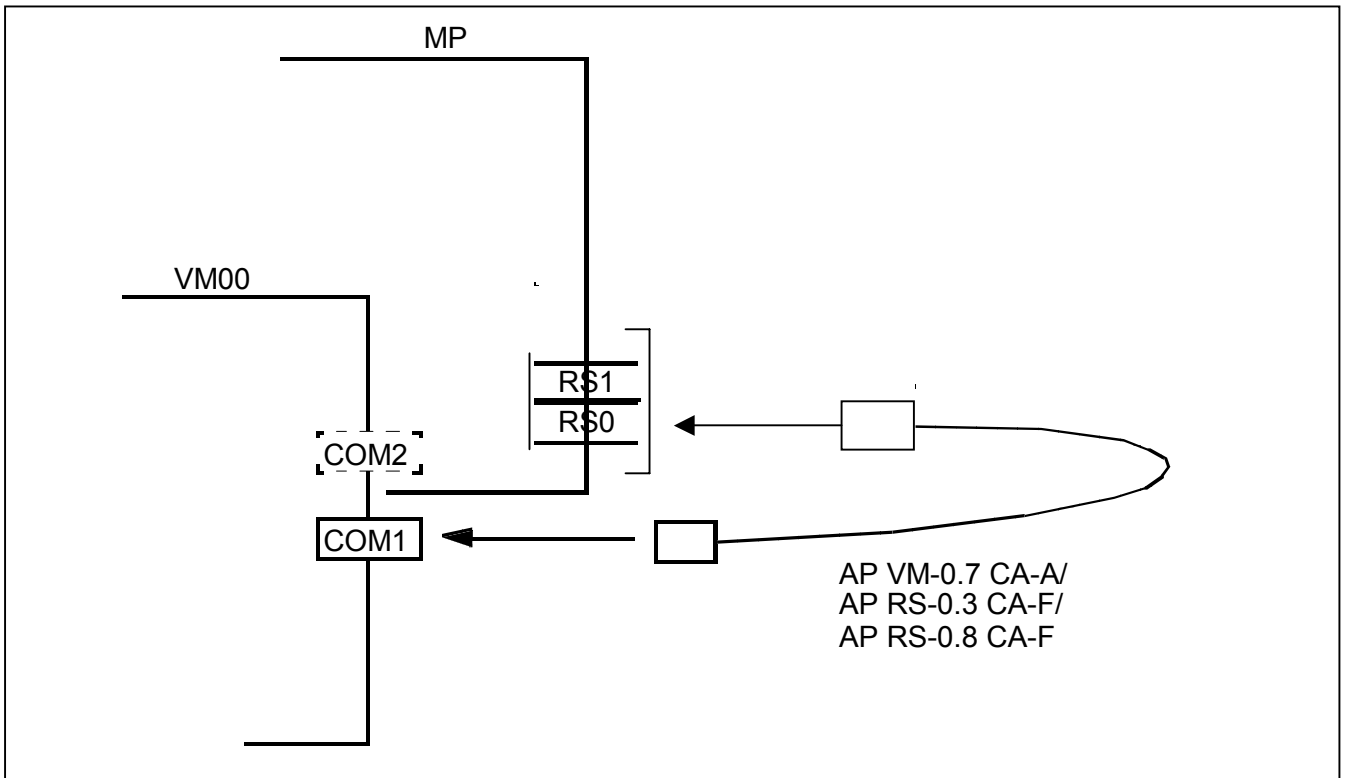

Fig 4-13 LC to VM00 connection for a 64 port PIM

4.6 Connection of MCI cable for download of VMS Soft Keys (IVS2000 ONLY)

The MCI cable is also used for a once-off download of VMS Soft Keys from PZ-VM00 to the MP card. The cable should be connected between Com port 1 on the PZ-VM00 and either RS0 or RS1 on the MP card. After this connection is made and programmed according to programming later on in this TIB, the PZ-VM00 can be initialised by setting the MB key on the PZ-VM00 card to the downward position and pressing the reset key on the PZ-VM00. The VM00 will download VMS Soft Key data to the MP during the later stages of its initialisation process. The status of this download can be checked using the commands described later in this TIB.

Note: The connection from the remote PC can be made as soon as the lamps PL0~PL3 are illuminated on the DSP card of the PN-VM00. The progress of boot up sequence can be viewed at this time. This includes the download of VMS SoftKeys from the AD-8 to the PABX CPU.



5 PROGRAMMING PROCEDURE

Two sections of programming must be completed for the NEAXMail AD-8 to operate. The first section is for the digital station ports of NEAXMail AD-8. The second section is for all Dterms in the PABX that require the Live Record feature. If required, the data for MCI and the internal modem must also be set.

CAUTION: *Before programming the PABX system data, set the MB switch on the VM00 card to ON (up position) and leave the MB switch ON while programming.*

5.1 Programming Digital Voicemail Ports

CM10

Assign the digital voice mail station number to the LEN.

- (1) 0000-0511: LEN (See previous chapter for suggested Len positions.)
000-511 (IVS 2000)
- (2) FX-FXXXX: Voice Mail Station Number

CM90 YY=00

For digital voice mail stations set by CM10 above, set three function keys and delete unused keys as below.

- (1) X-XXXX: Station Number + , + Key Number
 - (2) Station Number/ Function Number/ "CCC" to delete function code on key
- Set Station Number (FX-FXXXX) on key number 16
 - Set TRF (F1004) on key number 23 (Key 94 IVS 2000)
 - Set SPKR (F1016) on key number 21 (Key 96 IVS 2000)
 - Delete function code on key number 01 - key number 15, 17 - 20, 22, and 24 (90, 93, 95 + 97 IVS 2000)

CM90 YY=01

Set ringer activation to key number 16 of station number that you set above.

- (1) X-XXXX: Station Number + , + Key Number 16

CM93

Set Prime Line.

- (1) X-XXXX: Station Number
 - (2) X-XXXX: Station Number
- * (1) and (2) must be the same station number

CM17 Y=0

Build UCD Group for voice mail stations.

- (1) X-XXXX: Station Number A
- (2) X-XXXX: Station Number B

Note 1: *If you have more digital voice mail stations, repeat the above programming by referencing the Office Data Programming Manual.*

Note 2: *The pilot station (station A) of UCD Group must be a "Phantom Single Line Station". A Phantom Single Line Station is an analog station assigned in CM10 to a LEN with no card in that card slot.*

For example, assign in CM10, (1) LEN 0500, (2) XXXX (analog station)

CM17 Y=1

Set UCD pilot station.

- (1) Phantom Single Line Station Number assigned in CM10
- (2) Set "1".

CM17 Y-2

Assign all digital voice mail ports to the phantom single line station a UCD Group number.

(1) X-XXXX: Station Number (All voice mail ports including the pilot station)

(2) UCD Group Number (00-15)

CM08

Provide the periodic recording tone on live record.

(1) 109

(2) "0" = To be sent ** Australian regulations require a periodic tone to be sent when using live recording on the telephone systems. **

CM13 YY=24

Provide the digital voice mail port.

(1) X-XXXX: Station Number (Each digital voice mail port only)

(2) "0" = To be provided

CM51 YY=15

Set voice mail pilot station connected to the NEAXMAIL AD-8 per user's tenant number.

(1) 00-63: Tenant Number

(2) Voice Mail Pilot Station Number (phantom single line station number assigned in CM10)

Note : *This command is necessary for the Live Record feature.*

To provide unsupervised transfer to the Attendant Console:

CM08

Call transfer from a station before Attendant Console answers.

(1) 063

(2) "0"=To be provided/"1"=Not to be provided

To provide supervised transfer to the Attendant Console:

CM08

Allow unsupervised transfer.

(1) 125

(2) "0"=To be provided/"1"=Not to be provided

CM08

Allow Ring transfer for Call Transfer - All calls to a trunk (when station holds another station/trunk).

(1) 253

(2) "0"=Available /"1"=Not Available

5.2 Live Record Feature Programming

CM13 YY=03

Provide Message Waiting service.

- (1) X-XXXX: User Dterm Station Number (X-XXXX)
- (2) "0" = To be provided.

CM90 and CM93 below are required to activate live recording on user's terminal.

CM90 YY=00

The following live record features can be assigned to a Dterm user's keys.

- (1) My Line Number (Primary Extension Number) (X-XXXX) +, + Key Number (01-16)
- (2) F1091: Record
- F1092: Pause
- F1093: Re-record
- F1094: End
- F1095: Erase
- F1096: Address
- F1097: Urgent Page
- F1098: Voice Mail Key (Destination of CM51 YY=15)

CM93

Set Prime Line.

- (1) X-XXXX: Station Number
- (2) X-XXXX: Station Number

The following programming is to activate automatic live recording.

CM08

Specify whether live recording activates automatically on station-to-station incoming call.

- (1) 141
- (2) "0" = Start automatically / "1" = Not active

CM13 YY=23

Specify whether automatic live recording is provided by station base.

- (1) X-XXXX: Station Number
- (2) "0" = Start automatically / "1" = Not active

Note: When this command is activated, data assignments must also be made in CM08-141, CM35 YY=22, and/or CM76 Y=8.

CM35 YY=22

Specify whether automatic live recording is provided by trunk route base.

- (1) 00-63: Trunk Route Number
- (2) "0" = Start automatically / "1" = Not active

CM76 Y=8 (ICS)

Specify whether automatic live recording is provided for DID call. This command takes priority over CM35 YY=22.

- (1) X-XXXX: DID digits received
- (2) "0" = Start automatically / "1" = Not active

CM76 Y=13 (IVS 2000)

Specify whether automatic live recording is provided for DID call. This command takes priority over CM35 YY=22.

- (1) 000-999: Number Conversion Block No. assigned by CM76 Y=00
- (2) "0" : Not available
"1" : Start Automatically

5.3 Data Programming for MCI (Optional for CCIS No.7 ICS M120 only)

* Not required when the AD-8 is installed in the IVS 2000 PABX.

When setting up the MCI system, do the following AP initialization.

CM05

Assign an AP number to the AP00 card.

The AP number must match with the SENSE switch setting on the AP00 card.

- (1) 04-15: AP Number
- (2) "04" = AP00 Card

On the AP00 card, set the SW1 as below.

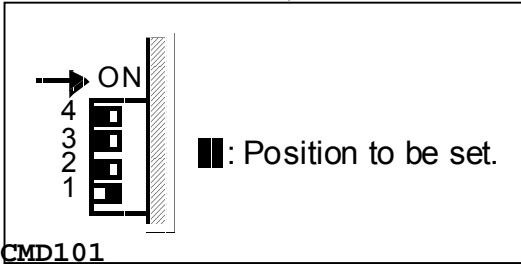

CMD101

Load the initial data into the AP00 card.

- (1) 0000
- (2) CCC

On the AP00 card, set the SW1 as below.

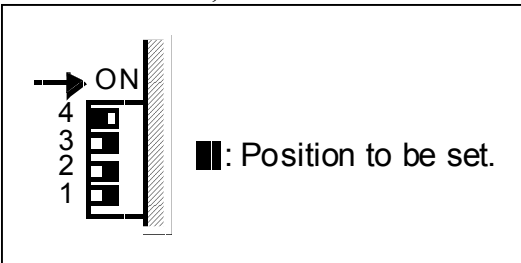

Note: After changing the SW1 as above, MP reset is required.

After AP initialization, set the required data for MCI.

CM08

Provide the system with VMS with MCI.

- (1) 443
- (2) 0: VMS with MCI

CM08

Provide MSG Display on the Dterm.

- (1) 025
- (2) 0/1: To be provided/Not to be provided

Note: When the second data is set to 0, "MSG" is displayed (the number of message is not displayed).

CM08

Specify Message Waiting Control from VMS with MCI to all stations.

- (1) 444
- (2) 0/1: Available/Not available

Note: In the CCIS network, this service is not available for the stations in opposite office.

CM08

Specify Message Waiting service from the VMS is provided for the called station when a forwarded call is terminated to the VMS via CCIS.

- (1) 376
- (2) 0/1: To be provided/Not to be provided

CM13 YY=03

Provide Message Waiting service for a station with MW lamp.

- (1) X-XXXX: Station Number
- (2) 0: To be provided

CM13 YY=10

Provide VMS service for a station port interface with the VMS (VMS station).

- (1) X-XXXX: Station Number (VMS station)
- (2) 0: To be provided

CM13 YY=22

Provide Momentary Open for a station port interface with the VMS (VMS station), as required.

- (1) X-XXXX: Station Number (VMS station)
- (2) 0: To be provided

CM90 YY=00

Assign the data to provide the MW lamp on a Dterm, if required.

- (1) My Line Number (Primary Extension Number) (X-XXXX) + , + Key Number
- (2) F1005

CMD000

Specify whether the text ("Message Waiting Control Text Sending is available") is sent to the VMS when the AP00 card is reset.

- (1) 136
- (2) 0/1: To be sent/Not to be sent

CMD000

Specify the number of digits for station number in the message format to communicate with the VMS.

- (1) 137
- (2) 0/1: 6 digits/8 digits

CMD001

Assign the attribute data of RS0-RS2 port used for MCI (RS3 ports can not be used).

RS1 port is recommended for standard use.

- (1) See the following table.
- (2) See the following table.

AP INITIALISATION IS REQUIRED AFTER SETTING THIS COMMAND

1st Data			Meaning	2nd Data	Meaning
Port 0	Port 1	Port 2			
20	24	28	Data Speed	2/3/4/5	1200/2400/4800/9600 bps Note 1
21	25	29	Stop Bit	0/1/2	1/1.5/2 bits Note 1
22	26	30	Data Length	0/1	7/8 bits Note 1
23	27	31	Parity	0	No parity Note 1
80	100	120	Function	24	MCI
81	101	121	Priority for Data Processing	0	1 st
85	105	125	Station Address (SA)	48	0
86	106	126	Unit Address (UA)	33	!
89	109	129	Timer for Detecting the End of Block	5	512 msec.
98	118	138	Inter-text Guard Timer	0/1/2/3/4	0-128/128-256/256-384/384-512/512-640 msec. Note 2

Note 1: This data should be assigned depending on the attribute of VMS application.

Note 2: When sending text successively to the VMS, assign the inter-text guard timer.

5.4 Data Programming for Advanced AAINFO/VMS Soft Keys

[IVS 2000 R2.1 software required]

5.4.1 Advanced AAINFO Assignment

CM08

Specify whether a Ringing signal/Live Record Start signal which includes caller information (such as station number and kind of calling party) is sent to the VMS.

- (1) 702
- (2) 0 : To send
1 : Not sent

CM08

Specify whether a Ringing signal/Live Record Start signal which includes caller information (such as station number and kind of calling party) of the opposite office is sent to the VMS when a call is terminated via CCIS.

- (1) 703
- (2) 0 : To send
1 : Not sent

CM08

Allow or restrict to send the following signals to the VMS.

- Busy signal
When the VMS forwards a call to a station/trunk and the station/trunk is busy
 - Answer signal
When the VMS forwards a call to a station/trunk and the station/trunk answers
 - Release signal
When a station/trunk hangs up while accessing the VMS
- (1) 704
 - (2) 0 : To send
1 : Not sent

CM08

Specify whether MW lamp on a station of the opposite office is controlled from the VMS via CCIS

- (1) 706
- (2) 0 : Available
1 : Not available

NOTE: For the message Waiting lamp control via CCIS analog interface, be sure to set the dummy CCH number 0 by CMA7 Y=00.

CM08

Specify whether the PABX will send the subline station number when accessing the VMS from a subline assigned on a Dterm.

- (1) 713
- (2) 0 : Subline station No.
1 : My line station No.

CM08

Allow Soft Keys for Call Screening feature.

- (1) 715
- (2) 0 : Available
1 : Not available

5.4.2 VMS Soft Key Assignment

CM08

Specify which RS-232C port on the MP card is used for downloading the VMS Soft Key data.

- (1) 900
- (2) 0 : Port 1
1 : Port 0

NOTE: When Port 1 is used for built-in modem, the Port 1 cannot be used for downloading the VMS Soft Key data.

CM40

Assign the function of the RS-232C port according to the following VMS specification

- Function : None
- Data length : 8 bit
- Parity check : Ineffective
- Stop bit : 1-Stop bit
- Data speed : 9600 bps

Y=00 Function

- (1) 0 : Port 0
1 : Port 1
- (2) None <: No Data

Y=01 Data length

- (1) 0: Port 0
1: Port 1
- (2) 1 < 8 bit

Y=02 Parity check

- (1) 0: Port 0
1: Port 1
- (2) 1 < Ineffective

Y=04 Stop bit

- (1) 0: Port 0
1: Port 1
- (2) 0 < 1-Stop bit

Y=08 Data speed

- (1) 0: Port 0
1: Port 1
- (2) NONE <: 9600 bps

CM13

Provide the VMS Soft Key feature to each VMS station.

Y=37

- (1) X-XXXXXXXX : VMS Station No.
- (2) 0 : To provide
1 : Not provided

CM12

Provide the VMS Soft Key feature to the required Dterms.

Y=22

- (1) X-XXXXXXXX : My line No.
- (2) 0 : Available (Dterm 75 series E/Elite)
1 : Not available (Dterm 65 series III/E-Pro)

If the VMS Soft Key feature operates improperly, or when the VMS software is renewed, download the VMS Soft Key data by CMEC Y=4

CMEC

Download the VMS Soft Key data from the VMS.

Y=4

- (1) X-XXXXXXXX : VMS Station No.
- (2) FF: Delete the VMS Soft Key data

After assigning the data, set the MB key switch on the VM00 card to the UP position and then DOWN position.

NOTE: When the 1st data of CMEC Y=4 is assigned, the download status can be displayed on the MAT/CAT as follows.

00 : Download is finished

01 : Now requesting download

02 : Now downloading

03 : Now waiting download

FF : Soft Key data is not downloaded

Confirm the downloading status by CMEC Y=4.

5.5 Data Programming for Internal Modem

When using the internal modem for remote maintenance, assign the following system data for the LC card that will accommodate the modem lines for the VM00 card.

CM10

Assign a station number for the internal modem to the circuit of the LC card that will accommodate the modem lines.

(1) 0000-0511: LEN

(2) X-XXXX: Station Number

CM13 YY=07

Specify the kind of station as a modem station.

(1) X-XXXX: Station Number assigned by CM10 above

(2) Set "0". (Modem Station)

CM12 YY=00

Specify the dialing signal type of the internal modem on the VM00 card.

(1) X-XXXX: Station Number assigned by CM10 above

(2) Set "1". (DP)

6 AD-8 CONFIGURATION

The loading and testing of the AD-8 software will be initially performed by Active Voice Australia. When the product is shipped to site it will contain a default configuration. While some aspects of the configuration can be deleted, it is advisable to maintain the System Administrator 'NEC' (also known as Amy Ronk). This will allow NEC to easily maintain the system.

The AD-8 was initially released with Q110 software (without MCI Integration), later with Q122 (with MCI Integration) and the current software – Q414H. The software version of the AD-8 can be found by pressing the **F5** key on the front Banner screen of the application.

6.1 Preferred Default settings

The AD-8 comes with a default setup, which makes configuring the system easy. It is only necessary to alter the existing data and to add mailboxes for subscribers. Care should be taken so that unnecessary default configurations do not interfere with the part of the configuration, which is used by the customer.

A default System Administrator 'Amy Ronk' with an ID 'NEC' comes with the system. This should be maintained to allow Remote access to the system. If the extension number conflicts with an existing numbering plan, then another number such as the modem number can be allocated to 'Amy Ronk'.

The System Operator has a default system ID of 0. This represents the number plan within the AD-8. This is mapped to the actual System Operator extension in the EASYMADE APPLICATION screen Page 3 of 6. The Attendant Console number can be placed here.

Note: By default, the American numbering plan is used.

Outdial Access code is set to 9 by default. In Australia, 9 is usually the Attendant Console and therefore this should be changed in the EASYMADE SWITCH SETUP Page 1, item 3.

6.2 Tone detection

By default, the tone specification that comes with the voicemail is satisfactory for Australian markets. However, there may be some fine-tuning required for some overseas markets where the tones may be slightly different. This is necessary to ensure that the Network disconnection tone can be detected in order to clear down the circuit when connecting with outside lines. A new tool called LEARNCP can be used to correct the problem. The tool will guide you through the necessary steps to complete this task. Please consult the NEAXMail AD-8 Rev 2 documentation for further information. This is only reqd when PABX / exchange tones vary from those normally used in Australia.

6.3 MCI configuration

The reason for using MCI integration is to provide Voicemail features for remotely connected subscribers via CCIS No.7. when the AD-8 is installed in the ICS 110/120 PABX. When MCI Integration is enabled, the Message Wait lamp is effective for remote users.

Note: The Message count facility is not available under MCI integration. This is only available under Dterm Integration (no MCI integration). Also, Dterm messages indicating Old & New messages are not available on remote Dterms.

There are 2 methods that can be used to configure the AD-8 for MCI, manually or automatically.

6.3.1 Manual MCI Configuration

(a). Voicemail extension numbers and the Pilot number must be registered in the EASYMADE APPLICATION screen Page 1 of 6, Item 7.

(b). Include the following entry in the SWITCH SETUP screen Page 1 of 3, Item 2

2. Integration Options S1:96N81=MCIx
(where x = 3 for 3 digit extension numbers or,
x= 4 for 4 digit extension numbers.)

and ensure that DT8 = 0

(c). Make the following change in the SWITCH SETUP screen Page 2 of 3, Item 10

10. Message Lamp On: @X
Off: @X

6.3.2 Automatic MCI Configuration

(a) Delete the switch name in the SWITCH SETUP screen Page 1 of 3 , Item 1 and then move the cursor which will force the AD-8 to prompt for a switch type. If you select NO to the first option (NEC PBX) and YES to the second option (NEC PBX W/MCI), the AD-8 will configure itself for MCI integration.

The integration options will now read

1. Integration Options NEAX S=MCI DT DT8=0 CR&,,,

(b) Change Item 4 (Transfer Options) on page 1 of 3 of the SWITCH SETUP from T to Q.

NOTE: If the LCR tables offer a second choice that is not a CCIS No.7 route (i.e. PSTN or ISDN) then remote extensions will not receive Lamp notification if calls have arrived via the second choice routes.

6.4 Upgrading from previous versions to Q414H.

The initial release of the AD-8 software was on version Q110 and after many versions in between the predecessor to Q414H was Q122. The latter supporting MCI integration and also requiring a Security Identification Number for subsequent updates of software.

Due to problems associated with on-site upgrades, we will be adopting the following procedure for ALL upgrades to version Q414H:

- STEP 1. Perform a backup of AD-8 data using either of the procedures described in section 6.5 of this TIB.
- STEP 2. Order a replacement AD-8 (PN-VM00) from NEC production through the normal FAR procedure. This system will come ready loaded with Q414H and have an Activation Code assigned.
- STEP 3. When the replacement AD-8 system arrives, the previously backed up data should be restored, again using the procedure described in section 6.5 of this TIB.
- STEP 4. The AD-8 can be rebooted by means of the reset key on the PN-VM00 and when running, the system should be tested for correct operation. (If VMS SoftKeys are to be used, the procedure described in 4.5 in this TIB should be followed.)

6.5 Backup, Archive and Restore

6.5.1 Definitions

The following definitions apply:

Backup is the transfer of all system data to offsite storage. In most cases the data from a NEAXMail AD-8 is backed up to a support PC.

Archive is the transfer of system database and user greetings to a second location on the NEAXMail AD-8 card. This process can be performed autonomously by the NEAXMail system.

Restore is the re-installation of the previously backed up data from the support PC to the NEAXMail AD-8.

6.5.2 Backup Feature

6.5.2.1 Description

The backup feature saves the entire state of the voice processing system at the time of backup. Archiving only stores part of the database, backup however, saves executables, the entire database, and all messages, greetings and voice names from the system.

Backup is performed manually and the technician must connect to NEAXMail through the serial port connection. AD-8 cannot be running during backup, and the procedure is not available through technician conversation (i.e. via phone access to the system) .

6.5.2.2 Backup Procedure

This is not a new procedure, but a re-written version of the procedure in the Activevoice Manual.

- Connect to voicemail system using co-session software from remote PC
- When at Active Voice VMM front screen, exit by pressing [esc], type ID (NEC) and return
- Enter 'y' to exit and disconnect all lines. This will disconnect all calls from VMM
- Press '3' to prepare for remote backup
- At this point, press [alt-left shift] this will return you to the co-session front screen
- Press F6 to disconnect from AD8
- Press F10 to exit to dos, this will return you to C:\REMOTE dir of remote PC
- Type backup from C:\REMOTE directory
- Press '3' for configure and confirm correct settings for backup. Ie. Connect type
- Save settings – press 'y' and enter
- Add to co-session phonebook 'y' call it 'backup'. This will bring you to backup menu.
- Press '1' for backup, 'y' to continue, 'n' to backup system prompts unless you require them
- Specify directory (on the remote PC) for your data to be sent to.
- Walk away from PC for about 40-50 mins. Backup complete
- Confirm correct operation of AD8 VMM system.
- Your directory (entered 3 steps above should contain 75 files including one hidden file)

6.5.3 Archive Feature

6.5.3.1 Description

The goal of the database archive is to allow a system that has suffered catastrophic data loss (or other failure) to restore itself to working condition. NEAXMail AD-8 retains a default system database as well as the two most recent databases. NEAXMail AD-8 checks daily to determine if the database should be archived. If necessary, the system builds a compressed file containing the system database and all user greetings. The compressed file is then moved to the **ARCHIVE** directory on the NEAXMail hard drive.

6.5.4 Restore Feature

6.5.4.1 Description

The purpose of the restore utility is to replace a previously backed up database to the NEAXMail AD-8 ensuring files are replaced into the correct locations.

6.5.4.2 Restore Procedure

- Follow steps 1 – 8 from above Backup procedure.
- Press '2' for restore
- Press 'y' to continue
- "Restore system prompts" – type 'y' if system prompts previously backed up, otherwise type 'n'
- Specify directory on remote PC that contains backup data to be restored.

NOTE: This directory must be on C:\ not A:\

- Type 'y' if correct, go to step 14 and 15 above

6.5.5 The BRU Utility

This is the new utility for back up, restore and updating the NEAXMail AD-8 software and database. The utility can be used to:

- Backup files after installation or before a major software update by transferring them to the support computer.
- Recover lost or corrupted files if the system crashes or equipment fails.
Update the AD-8 voicemail system to the latest software.
- **The BRU Host is included in all NEAXMail AD-8 voice messaging systems running software versions 6.65 Q412 or later.**

The BRU utility consists of two software programs, the BRU Host and the BRU Remote. The BRU Remote must be installed on the same support computer that you use to perform remote maintenance. This is in addition to Co Session software.

6.5.6 Other methods of backup, restore and archive

There are other forms of backup available for use with the AD-8 voicemail system by field technicians. A series of batch files have been created by David Rout from NEC and can be installed on the Hard disk of the AD-8 voicemail. These batch files greatly reduce the time taken to perform backups down to approximately 20mins. The messages and prompts are not backed up by this procedure but sometimes this is not entirely necessary. It should be noted that whilst excellent alternatives to those provided by Active Voice, are not supported in any way by Active Voice. Copies of these batch files will be distributed on the floppy disks provided with the PN-VM00.

7 SERVICE CONDITIONS

- If holding options are required for the System Operator, the System Operator cannot be an Attendant Console. For holding options to work, the AD-8 must hear a busy signal and the Attendant Console cannot return a busy signal.
- If holding options are required for a Transaction Box, the transfer destination of the Transaction Box cannot be an Attendant Console. For holding options to work, the AD-8 must hear a busy signal and the Attendant Console cannot return a busy signal.
- Message count is not supported by MCI message protocol and therefore not available under MCI integration.
- DOS Co Session is not supported under Windows NT, however a Windows version is available from the Artisoft Corporation, which will run under Windows NT. The batch files from the DOS based Co Session will need to be copied onto the Windows PC to enable the backup routines to occur.
- LCD multiple message display over CCIS No.7 is not supported.
- VMS Soft Keys are not supported from the remote CCIS No.7 office.
- VMS Live Record Keys or not supported from the remote CCIS No.7 office.
- VMS Live Recording can not be initiated from the remote CCIS No.7 office

8 MAINTENANCE

Regular maintenance activities occur when a DOS surrender is scheduled. This cleans up the databases used by the AD-8.

If a Hard Disk drive is suspected of failing, then the scandisk program can be run at the command prompt after exiting the voicemail. A surface scan will identify any bad sectors or clusters. There should be zero bad sectors or clusters. If they are found then the Hard Disk Drive must be replaced and a copy of the SCANDISK.LOG file sent with the unit. It would also be advisable to have a screen capture of the surface scan screen.